

Grid Interconnection of Renewable Energy Sources at the Distribution Level with Performance Comparison of Induction Generators

Sd.Shagufta Parveen¹S.Chandra Sekhar²T.Raghu³¹M.tech Scholar (PEED), Anurag Engineering College, Kodad, Telangana, India²Associate Professor & HOD (EEE), Anurag Engineering College, Kodad, Telangana, India³Associate Professor (EEE), Anurag Engineering College, Kodad, Telangana, India

Abstract—Renewable energy resources (RES) are being increasingly connected in distribution systems utilizing power electronic converters. This paper presents a novel control strategy for achieving maximum benefits from these grid-interfacing inverters when installed in 3-phase 4-wire distribution systems. The inverter is controlled to perform as a multi-function device by incorporating active power filter functionality. The inverter can thus be utilized as: 1) power converter to inject power generated from RES to the grid, and 2) shunt APF to compensate current unbalance, load current harmonics, load reactive power demand and load neutral current. All of these functions may be accomplished either individually or simultaneously. With such a control, the combination of grid-interfacing inverter and the 3-phase 4-wire linear/non-linear unbalanced load at point of common coupling appears as balanced linear load to the grid. This new control concept is demonstrated with extensive MATLAB/Simulink simulation studies and validated through digital signal processor-based laboratory experimental results. And the performance comparison of a wind power system based on two different induction generators as well as the experimental demonstration of a wind turbine simulator for the maximum power extraction. The two induction machines studied for the comparison are the squirrel-cage induction generator (SCIG) and the doubly fed induction generator (DFIG).

Index Terms—Active power filter (APF), distributed generation (DG), distribution system, grid interconnection, power quality (PQ), renewable energy.

I. INTRODUCTION

Electric utilities and end users of electric power are becoming increasingly concerned about meeting the growing energy demand. Seventy five percent of total global energy demand is supplied by the burning of fossil fuels. But increasing air pollution, global warming concerns, diminishing fossil fuels and their increasing cost have made it necessary to look towards renewable sources as a future energy solution.

Renewable energy source (RES) integrated at distribution level is termed as distributed generation (DG). The utility is concerned due to the high penetration level of intermittent RES in distribution systems as it may pose a threat to network in terms of stability, voltage regulation and power-quality (PQ) issues. Therefore, the DG systems are required to comply with strict technical and regulatory frameworks to ensure safe, reliable and efficient operation of overall network. With the advancement in power electronics and digital control technology, the DG systems can now be actively controlled to enhance the system operation with improved PQ at PCC. However, the extensive use of power electronics based equipment and non-linear loads at PCC generate harmonic currents, which may deteriorate the quality of power. Generally, current controlled voltage source inverters are used to interface the intermittent RES in distributed system. Recently, a few control strategies for grid connected inverters incorporating PQ solution have been proposed. In an inverter operates as active inductor at a certain frequency to absorb the harmonic current. But the exact calculation of network inductance in real-time is difficult and may deteriorate the control performance. A similar approach in which a shunt active filter acts as active conductance to damp out the harmonics in distribution network is proposed in. In, a control strategy for renewable interfacing inverter based on $p-q$ theory is proposed. In this strategy both load and inverter current sensing is required to compensate the load current harmonics.

The non-linear load current harmonics may result in voltage harmonics and can create a serious PQ problem in the power system network. Active power filters (APF) are extensively used to compensate the load current harmonics and load unbalance at distribution level. This results in an additional hardware cost. However, in this paper authors have incorporated the features of APF in the, conventional inverter interfacing renewable with the grid, without any additional hardware cost.

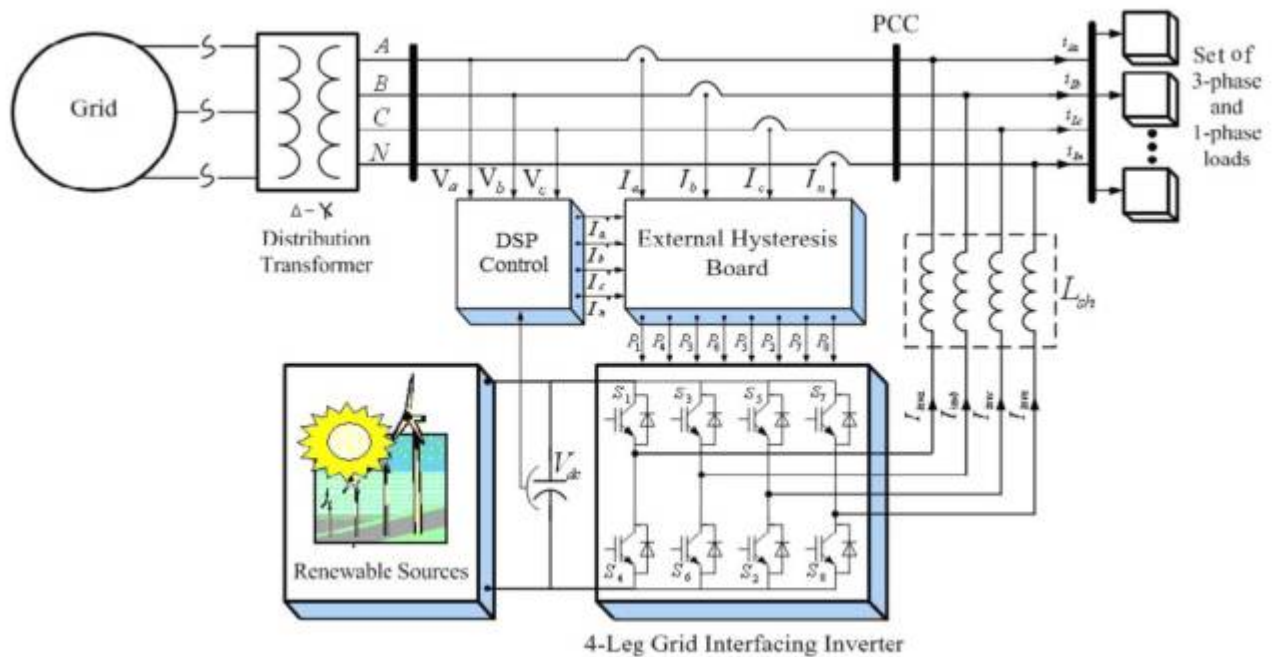

Fig.1 Schematic of proposed renewable based distributed generation system

II. DESCRIPTION OF THE SYSTEM

A. Wind Turbine

Wind turbines are used to convert the wind power into electric power. Electric generator inside the turbine converts the mechanical power into the electric power. Wind turbine systems are available ranging from 50W to 2-3 MW. The energy production by wind turbines depends on the wind velocity acting on the turbine. Wind power is used to feed both energy production and consumption demand, and transmission lines in the rural areas.

On the other hand, power production capacity based classification has four subclasses.

- Small Power Systems
- Moderate Power Systems
- Big Power Systems
- Megawatt Turbines

B. Voltage Source Converter (VSC)

A Voltage Source Converter (VSC) is a power electronic device that connected in shunt or parallel to the system. It can generate a sinusoidal voltage with any required magnitude, frequency and phase angle. It also converts the DC voltage across storage devices into a set of three phase AC output voltages. It is also capable to generate or absorbs reactive power. If the output voltage of the VSC is greater than AC bus terminal voltages, is said to be in capacitive mode.

So, it will compensate the reactive power through AC system. The type of power switch used is an IGBT in anti-parallel with a diode. The three phase four leg VSI is modelled in Simulink by using IGBT.

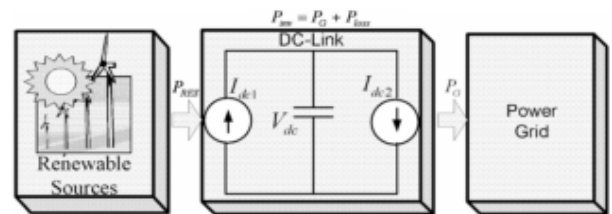

Fig. 2. DC-Link equivalent diagram.

A. DC-Link Voltage and Power Control Operation

Due to the intermittent nature of RES, the generated power is of variable nature. The dc-link plays an important role in transferring this variable power from renewable energy source to the grid. RES are represented as current sources connected to the dc-link of a grid-interfacing inverter. Fig. 2 shows the systematic representation of power transfer from the renewable energy resources to the grid via the dc-link. The current injected by renewable into dc-link at voltage level can be given as

$$I_{dc1} = \frac{P_{RES}}{V_{dc}}$$

The current flow on the other side of dc-link can be represented as,

$$I_{dc2} = \frac{P_{INV}}{V_{dc}} = \frac{P_G + P_{LOSS}}{V_{dc}}$$

B. Control of Grid Interfacing Inverter

The control diagram of grid- interfacing inverter for a 3-phase 4-wire system is shown in Fig. 3. The fourth leg of inverter is Used to compensate the neutral current of load. The main aim of proposed approach is to regulate the power at PCC during:

$$P_{RES} = 0 \quad P_{RES} < \text{total load power } (P_L)$$

$$P_{RES} > P_L$$

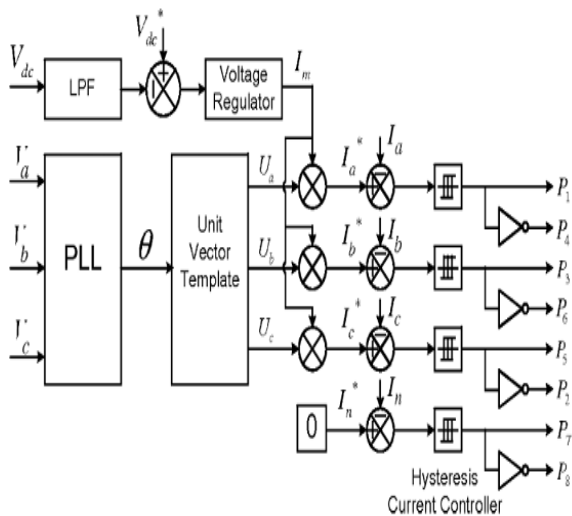

Fig. 3. Block diagram representation of grid-interfacing inverter control.

The grid synchronizing angle (Θ) obtained from phase locked loop (PLL) is used to generate unity vector template

$$U_a = \sin(\theta) \tag{1}$$

$$U_b = \sin(\theta - \frac{2\pi}{3}) \tag{2}$$

$$U_c = \sin(\theta + \frac{2\pi}{3}). \tag{3}$$

The instantaneous values of reference three phase grid currents are compute as

$$I_a^* = I_m \cdot U_a \tag{4}$$

$$I_b^* = I_m \cdot U_b \tag{5}$$

$$I_c^* = I_m \cdot U_c. \tag{6}$$

The neutral current is considered as

$$I_n^* = 0 \tag{7}$$

The reference grid currents(I_a^* , I_b^* , I_c^* and I_n^*) are compared with actual grid currents(I_a , I_b , I_c and I_n) to

compute the current errors as

$$I_{aERR} = I_a^* - I_a \tag{8}$$

$$I_{bERR} = I_b^* - I_b \tag{9}$$

$$I_{cERR} = I_c^* - I_c \tag{10}$$

$$I_{nERR} = I_n^* - I_n. \tag{11}$$

These error signals are given to hysteresis current controller then generates the switching pulses for six IGBTs of the grid interfacing inverter.

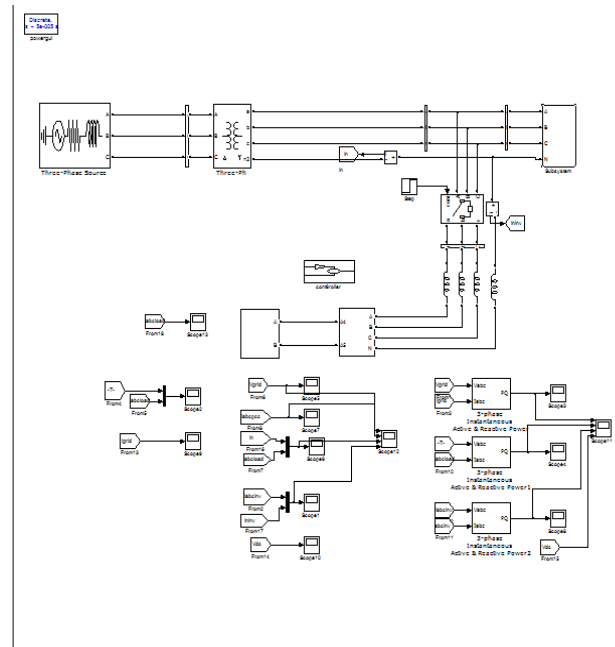

Fig.4 Matlab/Simulink Circuit

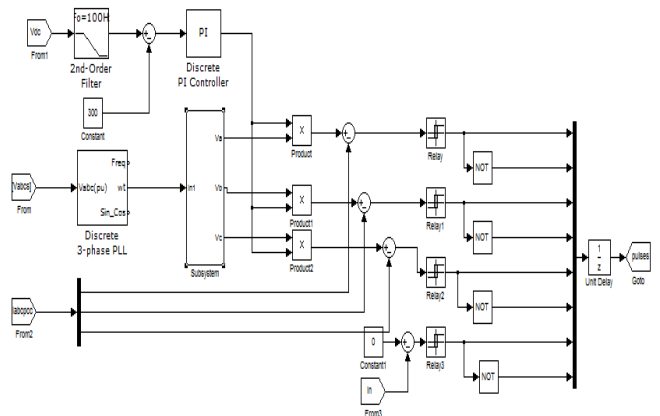

Fig. 5 controller circuit

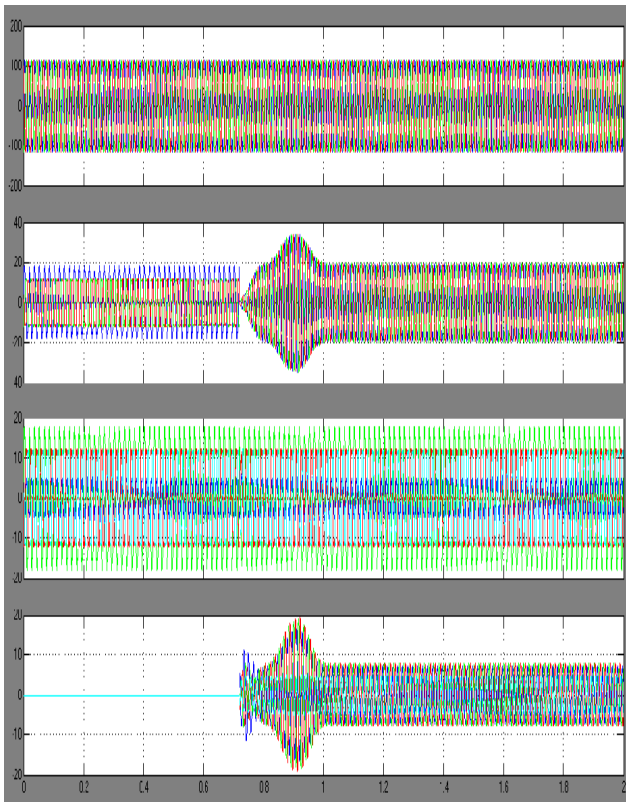

Fig. 6 Combined wave forms of grid voltage, current, load current, and inverter current.

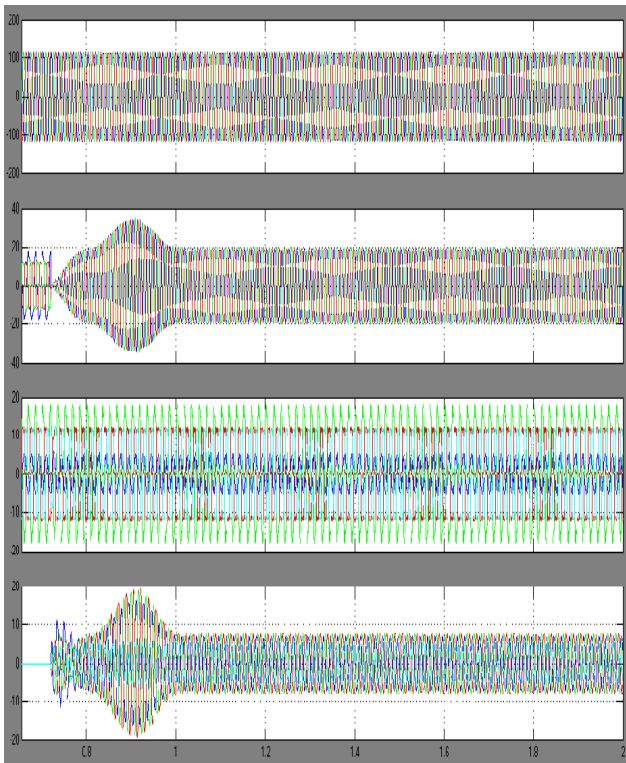

Fig. 7 wave forms of grid voltage, current, load current, and Inverter current after load.

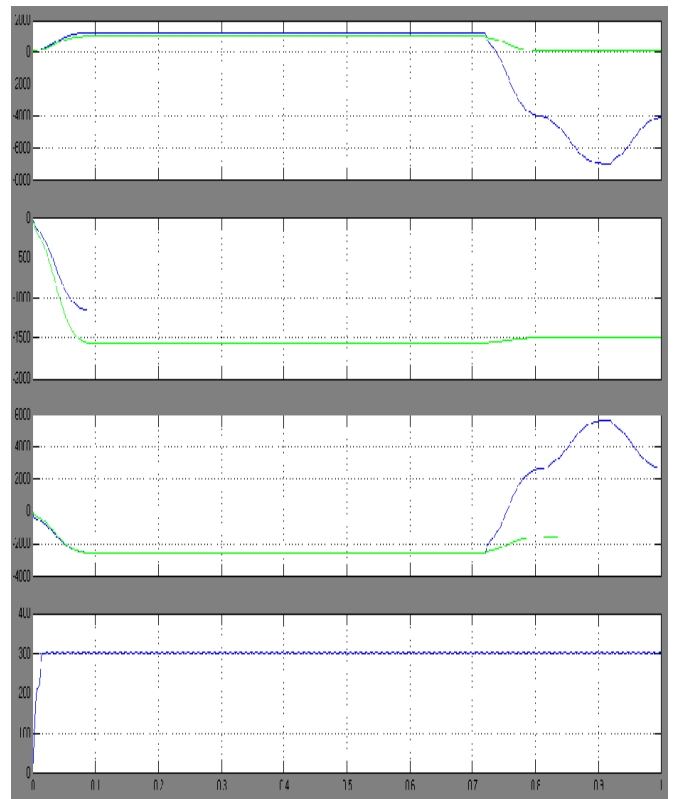

Fig. 8 wave forms of grid, load active and reactive power, inverter Injecting and dc link voltage.

In order to verify the proposed control approach to achieve multi-objectives for grid interfaced DG systems connected to a 3-phase 4-wire network, an extensive simulation study is carried out using MATLAB/Simulink. A 4-leg current Controlled voltage source inverter is actively controlled to achieve balanced sinusoidal grid currents at unity power factor (UPF) despite of highly unbalanced nonlinear load at PCC under varying renewable generating conditions. A RES with variable output power is connected on the dc-link of grid interfacing inverter. An unbalanced 3-phase 4-wire nonlinear load, whose unbalance, harmonics, and reactive power need to be compensated, is connected on PCC.

Initially, the grid-interfacing inverter is not connected to the network (i.e., the load power demand is totally supplied by the grid alone). Therefore, before time $t = 0.72s$, the grid current profile is identical to the load current profile. At $t = 0.72s$, the grid-interfacing inverter is connected to the network. At this instant the inverter starts injecting the current in such a way that the profile of grid current starts changing from unbalanced non linear to balanced sinusoidal current as shown.

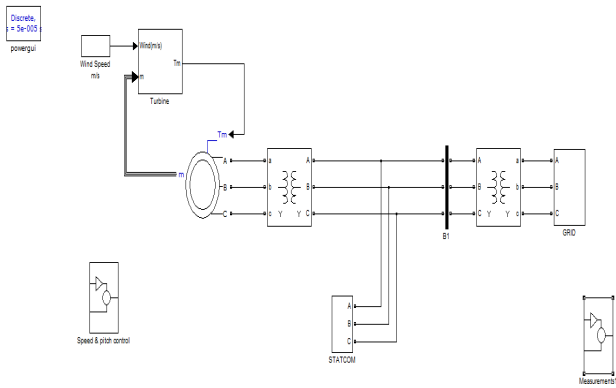

Fig. 9 SCIG Simulink Circuit

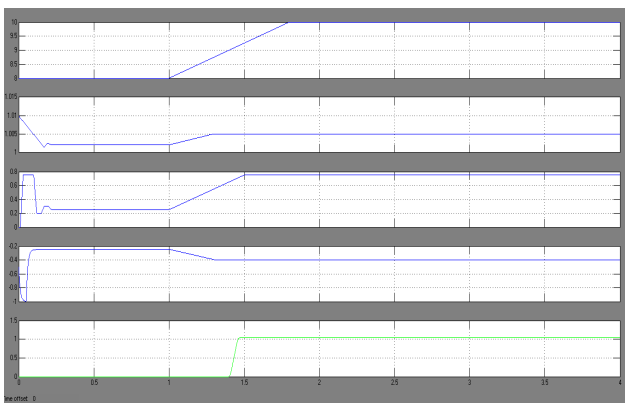

Fig. 10 Simulation results for SCIG system: (a) Wind speed v ; (b) Generator speed ω_r ; (c) active power P ; (d) reactive power Q ; (e) Pitch angle β .

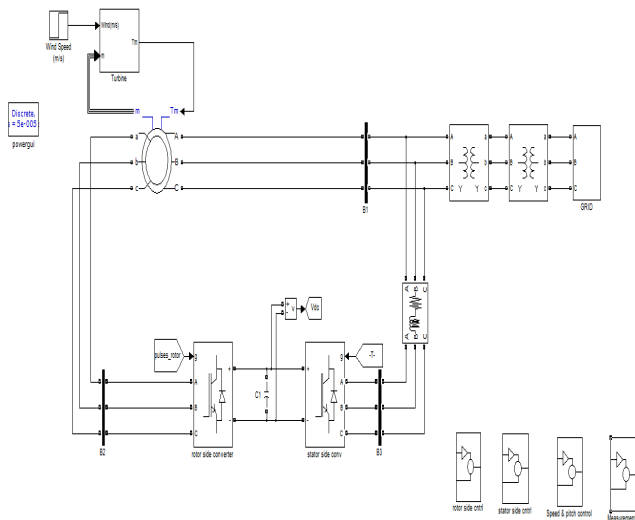

Fig. 11 DFIG Simulink Circuit

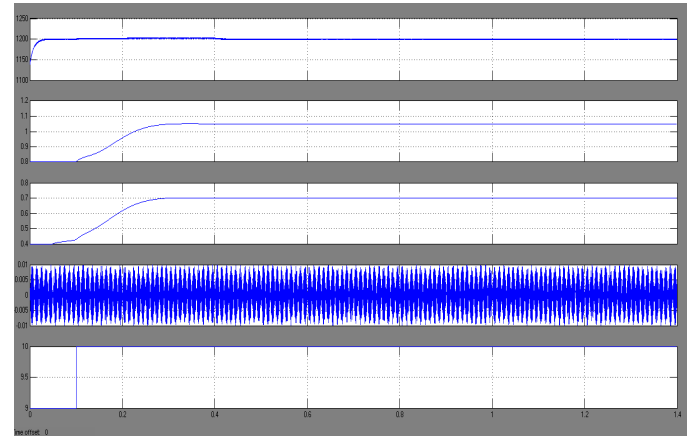

Fig.11 Wind step response. (a) DC-link voltage V_{dc} . (b) Rotor speed ω_r . (c) Active power P . (d) Reactive power Q . (e) Wind speed v_w .

III. CONCLUSION

This project has presented a novel control of an existing grid interfacing inverter to improve the quality of power at PCC for a 3-phase 4-wire DG system. It has been shown that the grid-interfacing inverter can be effectively utilized for power conditioning without affecting its normal operation of real power transfer. The grid-interfacing inverter with the proposed approach can be utilized to: i) Inject real power generated from RES to the grid, and/or, ii) Operate as a shunt Active Power Filter (APF). It is further demonstrated that the PQ enhancement can be achieved under three different scenarios: 1) $P_{RES}=0$, 2) $P_{RES} < P_{Load}$, and 3) $P_{RES} > P_{Load}$. The current unbalance, current harmonics and load reactive power, due to unbalanced and non-linear load connected to the PCC, are compensated effectively such that the grid side currents are always maintained as balanced and sinusoidal at unity power factor. Moreover, the load neutral current is prevented from flowing into the grid side by compensating it locally from the fourth leg of inverter. When the power generated from RES is more than the total load power demand, the grid-interfacing inverter with the proposed control approach not only fulfils the total load active and reactive power demand (with harmonic compensation) but also delivers the excess generated sinusoidal active power to the grid at unity power factor. And the performance comparison of a wind power system based on two different induction generators as well as the experimental demonstration of a wind turbine simulator for the maximum power extraction. The two induction machines studied for the comparison are the squirrel-cage induction generator (SCIG) and the doubly fed induction generator (DFIG).

REFERENCES

- [1] Mukhtiar Singh, Mukhtiar Singh, Mukhtiar Singh, and Rajiv K. Varma, "Grid Interconnection of Renewable Energy Sources at the Distribution Level with Power-Quality Improvement Features", *IEEE Trans. Power Delivery*, Vol. 26, No. 1, January 2011.
- [2] J. M. Guerrero, L. G. de Vicuna, J. Matas, M. Castilla, and J. Miret, "A wireless controller to enhance dynamic performance of parallel inverters in distributed generation systems," *IEEE Trans. Power Electron.*, vol. 19, no.5, pp.1205–1213, Sep.2004.
- [3] J. H. R. Enslin and P. J. M. Heskes, "Harmonic interaction between a large number of distributed power inverters and the distribution network," *IEEE Trans. Power Electron.*, vol. 19, no. 6, pp. 1586–1593, Nov. 2004. *Trans. Power Electron.*, vol. 19, no. 6, pp. 1586–1593, Nov.2004.
- [4] U. Borup, F. Blaabjerg, and P. N. Enjeti, "Sharing of nonlinear load in parallel-connected three-phase converters," *IEEE Trans. Ind. Appl.*, vol. 37, no. 6, pp. 1817–1823, Nov./Dec.2001.
- [5] P. Jintakosonwit, H. Fujita, H. Akagi, and S. Ogasawara, "Implementation and performance of cooperative control of shunt active filters for harmonic damping throughout a power distribution system," *IEEE Trans. Ind. Appl.*, vol. 39, no. 2, pp. 556–564, Mar./Apr. 2003.
- [6] J. P. Pinto, R. Pregitzer, L. F. C. Monteiro, and J. L. Afonso, "3-phase 4-wire shunt active power filter with renewable energy interface," presented at the Conf. IEEE Renewable Energy & Power Quality, Seville, Spain, 2007.
- [7] F. Blaabjerg, R. Teodorescu, M. Liserre, and A. V. Timbus, "Overview of control and grid synchronization for distributed power generation systems," *IEEE Trans. Ind. Electron.*, vol. 53, no. 5, pp. 1398–1409, Oct. 2006.
- [8] B. Renders, K. De Gussemme, W. R. Ryckaert, K. Stockman, L. Vandeveldel, and M. H. J. Bollen, "Distributed generation for mitigating voltage dips in low-voltage distribution grids," *IEEE Trans. Power. Del.*, vol. 23, no. 3, pp. 1581–1588, Jul. 2008.
- [9] V. Khadkikar, A. Chandra, A. O. Barry, and T. D. Nguyen, "Application of UPQC to protect a sensitive load on a polluted distribution network," in *Proc. Annu. Conf. IEEE Power Eng. Soc. Gen. Meeting*, 2006, pp. 867–872.
- [10] P. Rodríguez, J. Pou, J. Bergas, J. I. Candela, R. P. Burgos, and D. Boroyevich, "Decoupled double synchronous reference frame PLL for power converters control," *IEEE Trans. Power Electron*, vol. 22, no. 2, pp. 584–592, Mar. 2007.
- [11] M. Orabi, T. Ahmed, and M. Nakaoka, "Efficient performances of induction generator for wind energy utilization," in *Proc. 30th Annu. Conf. IEEE Ind. Elect. Soc.*, Nov. 2004, pp. 838–843.
- [12] M. Molinas, J. A. Suul, and T. Undeland, "Low voltage ride through of wind farms with cage generators: STATCOM versus SVC," *IEEE Trans. Power Electron.*, vol. 23, no. 3, pp. 1104–1117, May 2008.
- [13] Z. Chen, J. M. Guerrero, and F. Blaabjerg, "A review of the state of the art of power electronics for wind turbines," *IEEE Trans. Power Electron.*, vol. 24, no. 8, pp. 1859–1875, Aug. 2009.



First Author: Sd.Shagufta Parveen, Pursuing her M.Tech (PEED) from Anurag Engineering College, Kodad, and completed her B.Tech Anurag Engineering College, Kodad in 2013.



Second Author: S.Chandra Sekhar received his B.Tech Degree in Electrical & Electronics Engineering from RVR&JC college of Engineering; GUNTUR in 2001, M.Tech (High Voltage Engineering) degree in Electrical and Electronics Engineering from University College of Engineering, JNTU, Kakinada in 2004. He is pursuing Ph.D at K L University. Presently he is working as associate professor and Head of the Department of EEE in Anurag Engineering College. He has publications in Eight international journals. He is guiding both undergraduate and post graduate student projects. His area of interest includes Micro Grids, High voltage transmission and Power Systems.



Third Author: T.Raghu completed his B.Tech and M.Tech in power electronics From JNTUH, Hyderabad. Presently he is working as associate professor, Department of EEE in Anurag Engineering College .his interested areas are research in power electronics applications in power systems, electrical machines, FACTS & HVDC applications.